

CD Player D730/731 Out-of-Speed Control

- **Reason**

Recently, we finally discovered that the series regulator LM317 (IC 905) increases its output voltage when aging. The series regulator from National Semiconductor is heating up and collapses. The voltage rises up to 12 Volts. Due to this fact, IC703 (HEF4750 on Mainboard 1.630.152.XX) is supplied with excess voltage and is damaged.

To prevent this causal problem, we recommend to cool the regulator(s) as follow.

- **Solution**

The regulator's heat is dissipated by a heat sink, and IC 703 (frequency synthesizer) HEF4560 must be replaced, if having been supplied with excess voltage. At this occasion, we strongly recommend to add an other heat sink to the negative regulator (IC 903), too. By these actions, the chip temperature drops for both regulators.

- **Modification**

1. Unsolder the series regulator LM317T (IC 905). Add a heat sink (50.20.0002) to a new LM317T (50.10.0104 - Motorola). Apply thermal compound, if available. Mount the heat sink with an Allen-head screw (21.53.9354) to the LM317. Do not cut the regulator's terminals in order to avoid heat accumulation when mounted.
2. Reinstall the regulator to the PCB, leaving the terminal leads as long as possible. Take care that the heat sink is completely isolated from any component. Bend the regulator's terminals carefully in such a way that the heat sink does not touch C913.
3. Add an other heat sink (50.20.0002) to the LM337T (IC 903), as described above with LM317T. Usually, it is not necessary to replace the regulator LM337T (50.10.0105) by a new device ⁽¹⁾, unless it is obviously defective.
4. Replace the defective IC 703 (refer to page 2 - HEF4750V, 50.99.0179)

- **Bill of Materials**

Spare Part	Studer Order Number	Reference	Count
Heat sink	50.20.0002	to IC903 and IC905	2
Allen-head screw M3x6	21.53.9354	to IC903 and IC905	2
LM 317T Motorola	50.10.0104	IC905	1
LM 337T ^(1 refer to item - 3.)	50.10.0105	IC903	1
HEF4750V	50.99.0179	IC703	1

Component Layout of PCB 1.630.152.20 and later

STUDER D730 / D731

Jumper settings analog outputs:

STEREO:

MONO:

JMP 451:

JMP 401:

MAIN BOARD 1.630.152.23 / 1.630.152.24 / 1.630.152.26 / 1.630.152.28

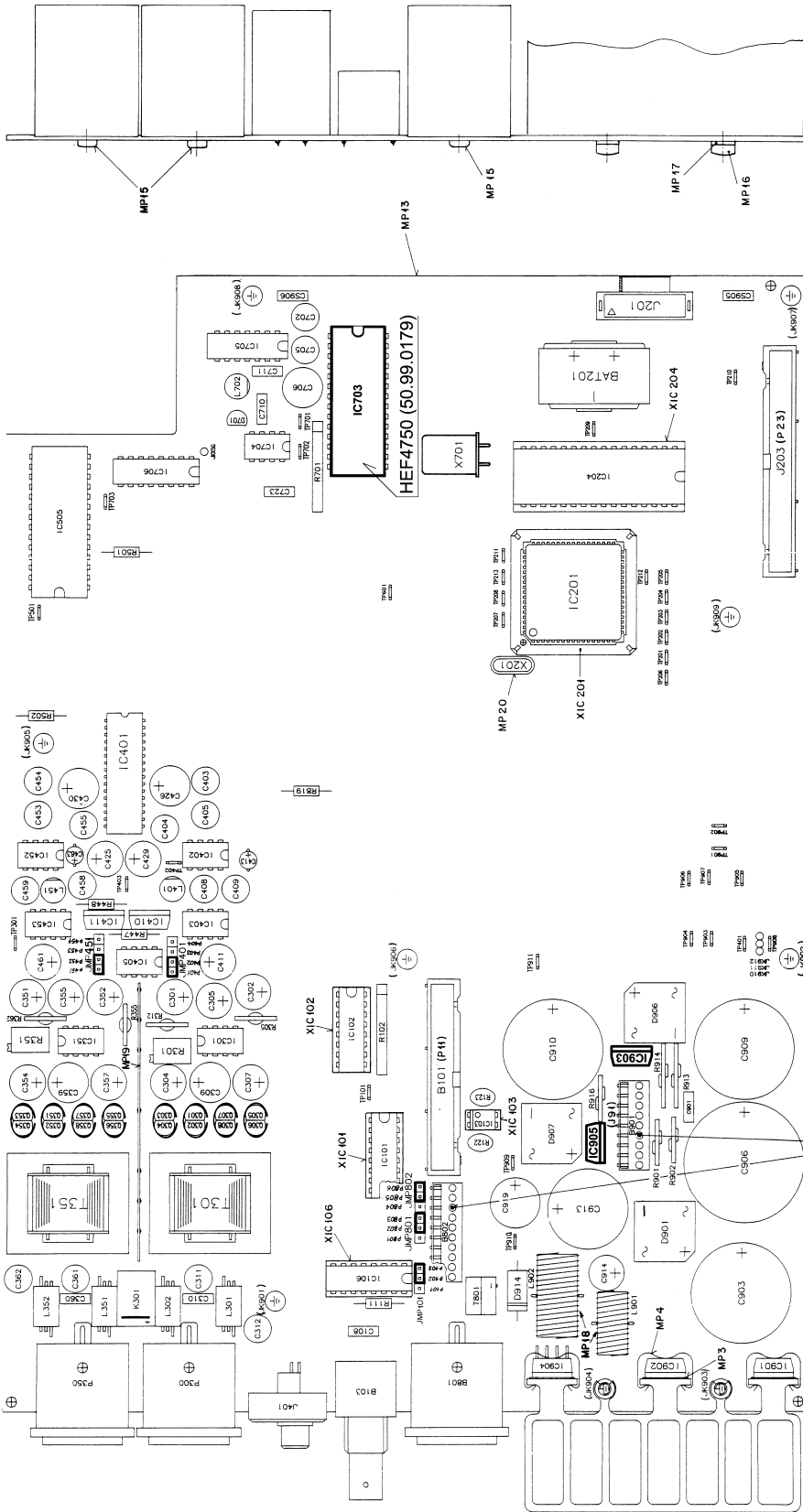

Part No.	Qty	Part Name	Unit	Order	Notes
1.630.152.23	1	MAIN BOARD	PCB	1.630.152.23	
1.630.152.24	1	MAIN BOARD	PCB	1.630.152.24	
1.630.152.26	1	MAIN BOARD	PCB	1.630.152.26	
1.630.152.28	1	MAIN BOARD	PCB	1.630.152.28	

STUDER	BRAND	1.630.152.
MEASUREMENT	BRAND	
ZUSATZ	BRAND	

component side

KEY

IC905, LM317T (50.10.0104)

Allen Key Screw (21.53.9354)

IC903, LM337T (50.10.0105)

Heatsink (50.20.0002)

Optional SFC board:

no SFC board (44.1kHz):

JMP 101

JMP 801 JMP 802

with SFC board

5/41

Section of Circuit diagram of PCB 1.630.152.20 and later

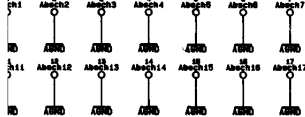
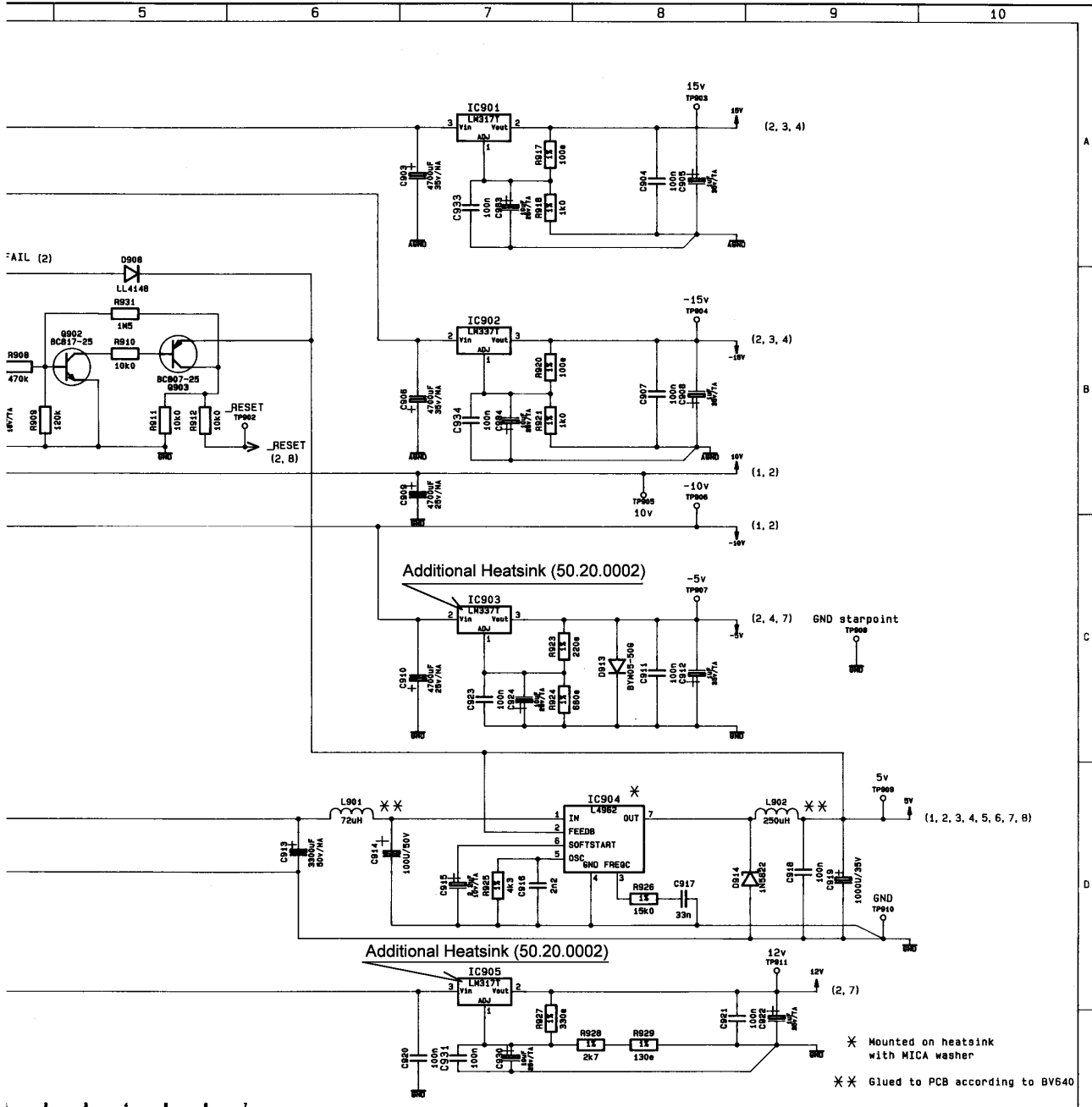

3					VISK			
2					NORM			
1					AVOR			
Ausg	AM-NR.	DATUM	BEARB	GES	ERST	9.9.93		
STUDER					MASST			

D730 MAIN-BOARD ESE POWER_SUPPLY		TEIL	B
		WTEIL	
1.630.152-23		ERSATZ	Ausg. 2
		STATUS	1
ZUGEH. UNTERLAGEN: Siehe_B1.1		KUNDE	STUDER
		BLATT:	VON 9